

## DC charging cable - EV-T2HPCC-DC500A-5,0M50ECBK11 - 1085638

Please be informed that the data shown in this PDF Document is generated from our Online Catalog. Please find the complete data in the user's documentation. Our General Terms of Use for Downloads are valid (<http://phoenixcontact.com/download>)



CHARX connect, HPC DC charging cable with cooled vehicle charging connector and cooled cable, Housing color black-black, with replaceable mating face frame, without panel feed-through, For charging electric vehicles (EV) with direct current (DC), for installation at charging stations for electromobility (EVSE), CCS type 2, Combined Charging System, IEC 62196-3-1, 500 A / 1000 V (DC), HPC, "PHOENIX CONTACT" logo, cable: 5 m, black, straight

### Product Description

DC charging cable with Vehicle Connector and open cable end for fast charging of electric vehicles (EV) with direct current (DC) via CCS type 2 Vehicle Inlets, for installation at charging stations for E-Mobility (EVSE)

### Your advantages

- ✓ Consistent design of all Phoenix Contact Vehicle Connectors and Infrastructure Plugs
- ✓ Silver-plated surface of the power and signal contacts
- ✓ Developed and produced in accordance with the IATF 16949 automotive standard and ISO 9001
- ✓ Convenient handling, thanks to the ergonomic handle and additional, rubber grip components
- ✓ Flexible and easily managed, slim charging cable, thanks to integrated cooling
- ✓ Integrated temperature sensors for monitoring the temperature at the power contacts and in the vehicle connector
- ✓ Additional safety thanks to integrated leakage sensors and a wear indicator in the cable sheath
- ✓ Convenient communication interfaces via CAN bus and digital output
- ✓ Maintenance-friendly replacement of the mating face frame without draining the coolant
- ✓ Service-friendly replacement of the mating face frame



### Key Commercial Data

Packing unit	1 pc
GTIN	
GTIN	4055626874043
Weight per Piece (excluding packing)	4.000 g
Custom tariff number	85444290
Country of origin	Germany

# DC charging cable - EV-T2HPCC-DC500A-5,0M50ECBK11 - 1085638

## Technical data

### Product definition

Type	HPC DC charging cable
	with cooled vehicle charging connector and cooled cable
	Housing color black-black
	with replaceable mating face frame
	without panel feed-through
	with temperature sensors
Application	For charging electric vehicles (EV) with direct current (DC) for installation at charging stations for electromobility (EVSE)
Affixed logo	"PHOENIX CONTACT" logo
Design	HPC
Standards/regulations	IEC 62196-3-1
Charging standard	CCS type 2
	Combined Charging System
	High Power Charging
Charging mode	Mode 4
Cooling technology	Water-glycol mixture as coolant in the vehicle connector and in the cable

### Dimensions

Height	181.2 mm (Vehicle charging connector)
Width	72 mm (Vehicle charging connector)
Depth	285.2 mm (Vehicle charging connector)
Conductor length	5 m
Stripping length	250 mm ±5 mm

### Ambient conditions

Ambient temperature (operation)	-30 °C ... 40 °C
	max. 55 °C (dependent on the derating curve)
Ambient temperature (storage/transport)	-40 °C ... 60 °C
Max. altitude	5000 m (above sea level)
Degree of protection	IP54 (plugged in; when plugged in and ready to operate, the degree of protection is only ensued if both plug-in components are original products from Phoenix Contact or suitable standard-compliant products)

### Electrical properties

Charging power (nominal operation)	500 kW
Number of power contacts	3 (PE, DC+, DC-)
Rated current of power contacts	500 A
Rated voltage for power contacts	1000 V DC
Number of signal contacts	2 (CP, PP)

## DC charging cable - EV-T2HPCC-DC500A-5,0M50ECBK11 - 1085638

### Technical data

#### Electrical properties

Rated current for signal contacts	2 A
Rated voltage for signal contacts	30 V AC
Type of signal transmission	Pulse width modulation with modulated Powerline communication according to ISO/IEC 15118 / DIN SPEC 70121
Communication interfaces	CAN bus for reading the temperature and leakage sensor data
	Digital output for determining the functional status of the vehicle connector
Note on the connection method	cannot be disconnected
Resistor coding	1500 $\Omega$ (between PE and PP)
Temperature monitoring	2x NTC (replaceable, front DC contacts)
	2x NTC (DC power wires inside)

#### Mechanical properties

Insertion/withdrawal cycles	> 10000
Insertion force	< 100 N
Withdrawal force	< 100 N

#### Design

Design line	HPC
Mating face color	black
Color handle area	black
Label	8.9 mm x 28.9 mm (customer logo on request)

#### Material

Housing material	Plastic
Material handle area	Soft plastic
Material mating face	Plastic
Flammability rating	V0
Material surface of contacts	Ag

#### Cable

Cable structure	5 x 25 mm <sup>2</sup> + 7 x 0.75 mm <sup>2</sup>
Wiring standards/regulations	DIN EN 50620
Wiring class	Class 6
External cable diameter	35.7 mm $\pm$ 0.4 mm
Type of conductor	straight
Cable resistance	$\leq$ 0.00078 $\Omega$ /m (based on a power core, at an ambient temperature of 20°C)
Outer sheath, material	EVM-1 in accordance with EN 50620
External sheath, color	black
Minimum bending radius	535.5 mm (15 x diameter)

# DC charging cable - EV-T2HPCC-DC500A-5,0M50ECBK11 - 1085638

## Technical data

### Cable

Coolant	50 % water, 50 % glycol (recommended: Glysofor N)
Cooling hose diameter	1x 11.5 mm Supply hose 2x 8.8 mm Return hoses
Cable weight	max. 1720 kg/km

### Temperature sensors

Type of sensor	NTC
Shutdown temperature	90 °C

### Requirements for a cooling unit

Cooling capacity	600 W (Cable length: 3 m) 800 W (Cable length: 4 m) 900 W (Cable length: 5 m) 1050 W (Cable length: 6 m)
Flow rate	2 l/min
Operating pressure	1.00 bar ... 2.00 bar
Flow temperature	15 °C
Maximum permissible pressure	4.00 bar
Relief pressure	2.00 bar

### Environmental Product Compliance

China RoHS	Environmentally Friendly Use Period = 10; For details about hazardous substances go to tab "Downloads", Category "Manufacturer's declaration"
------------	--

## Drawings

Dimensional drawing

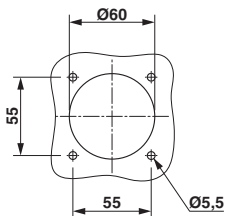

Drill hole spacing

Schematic diagram

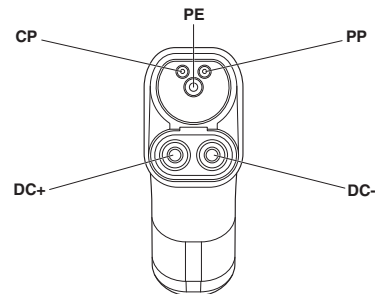

Pin assignment of the Vehicle Connector

# DC charging cable - EV-T2HPCC-DC500A-5,0M50ECBK11 - 1085638

Schematic diagram

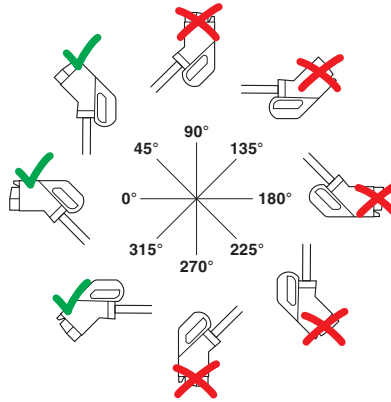

The resting position must be installed in the charging station such that the user cannot hang up the vehicle connector upside down (90° to 270°). However, positions rotated upward (45°) or downward (315°) are options for a resting position.

Dimensional drawing

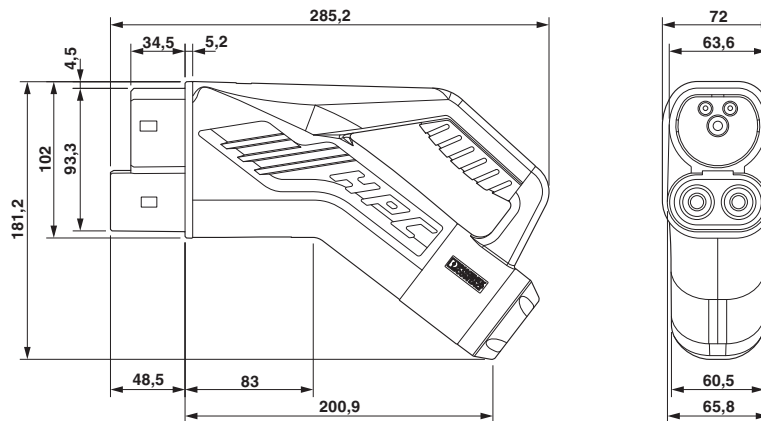

Make sure that the vehicle charging connector is placed in an appropriate charging connector holder, which ensures a minimum protection rating of IP24 in accordance with IEC 61851-1, for the entire time between charging. To create this charging connector holder, use the dimensions of the vehicle charging connector. Detailed dimensions can also be found in the Download area.

# DC charging cable - EV-T2HPCC-DC500A-5,0M50ECBK11 - 1085638

Schematic diagram

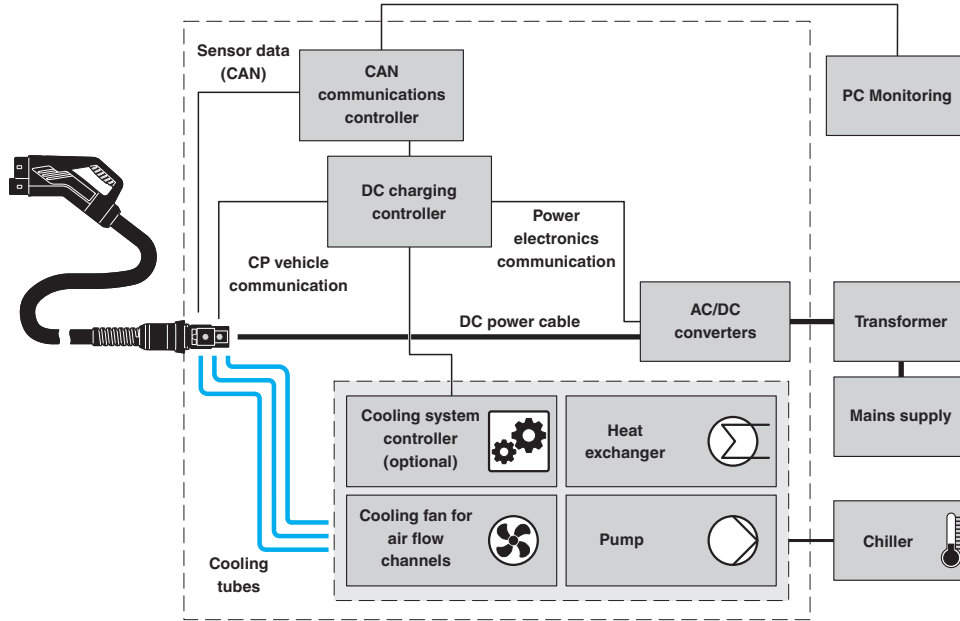

Central system: cooling unit and controller are positioned externally and supply multiple charging stations, each of which is equipped with a heat exchanger. The cooling is done actively using a chiller.

# DC charging cable - EV-T2HPCC-DC500A-5,0M50ECBK11 - 1085638

Schematic diagram

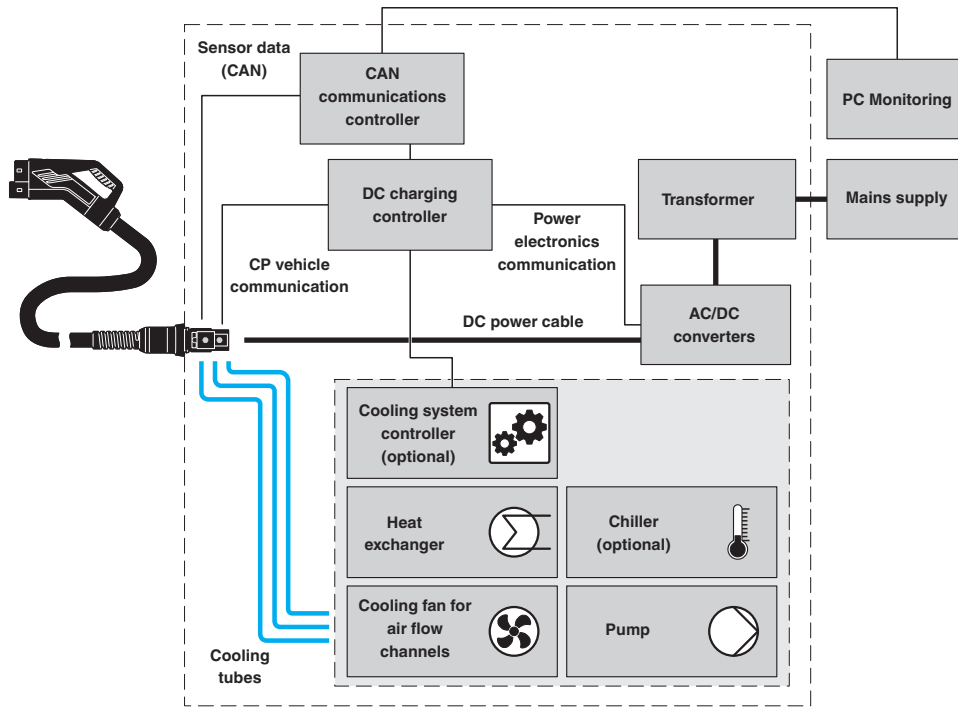

Standalone, decentralized system: cooling unit and controller are integrated into the charging station. The choice of cooling unit can be passive or active (i.e., with or without chiller).

Schematic diagram

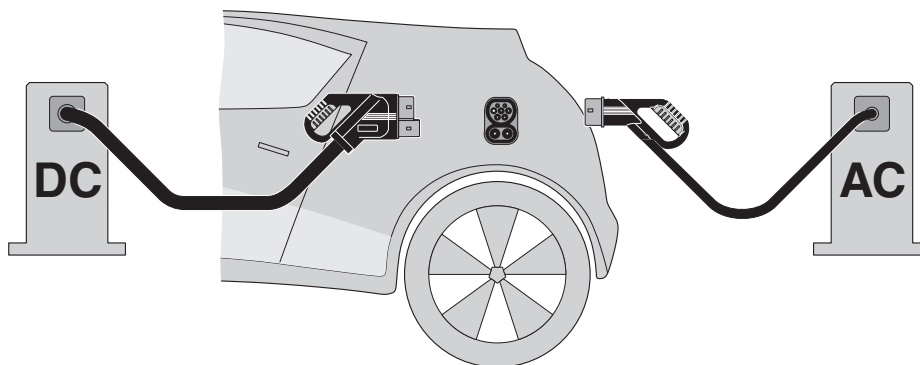

The Combined Charging System (CCS) principle - standard-compliant charging system for electric vehicles, which supports both conventional AC charging and fast DC charging. Both Vehicle Connectors fit into the CCS Vehicle Inlet.

# DC charging cable - EV-T2HPCC-DC500A-5,0M50ECBK11 - 1085638

Schematic diagram

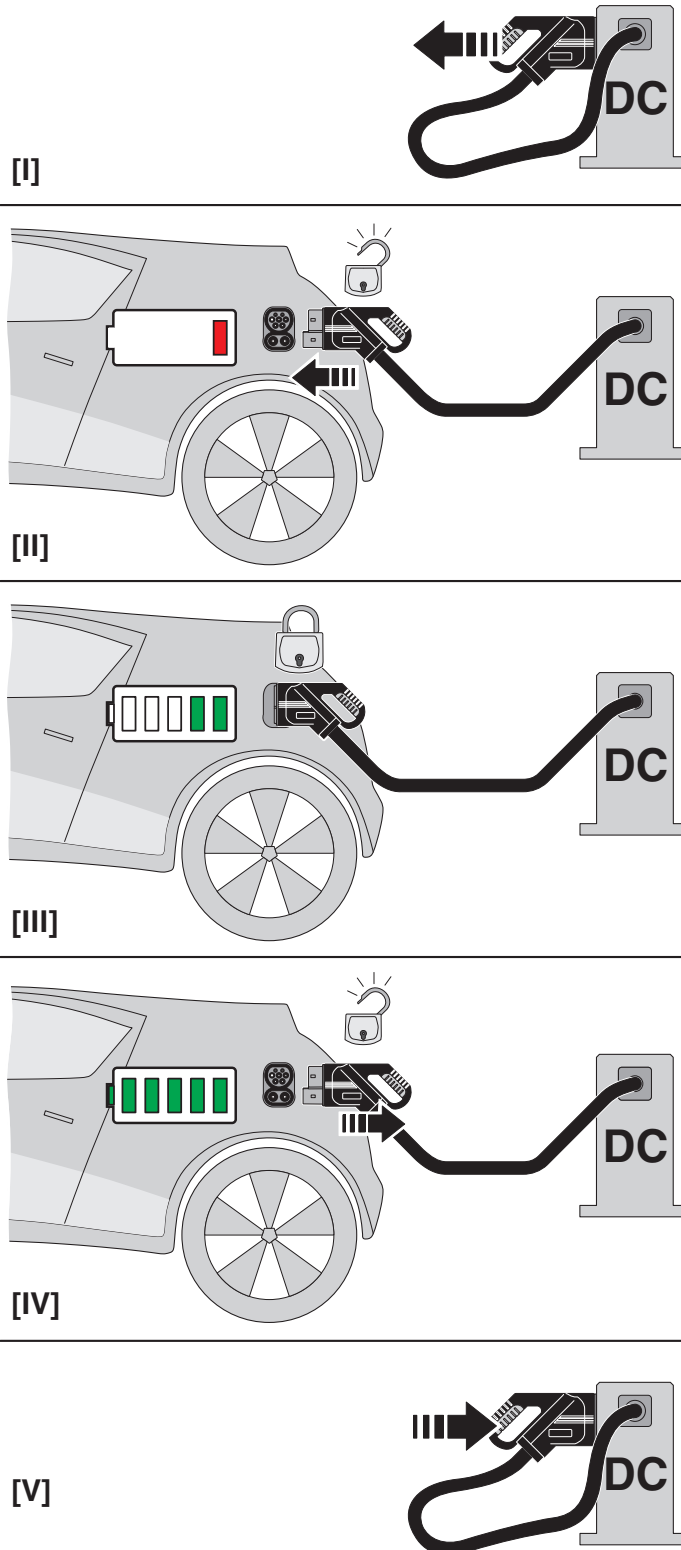

# DC charging cable - EV-T2HPCC-DC500A-5,0M50ECBK11 - 1085638

Schematic diagram

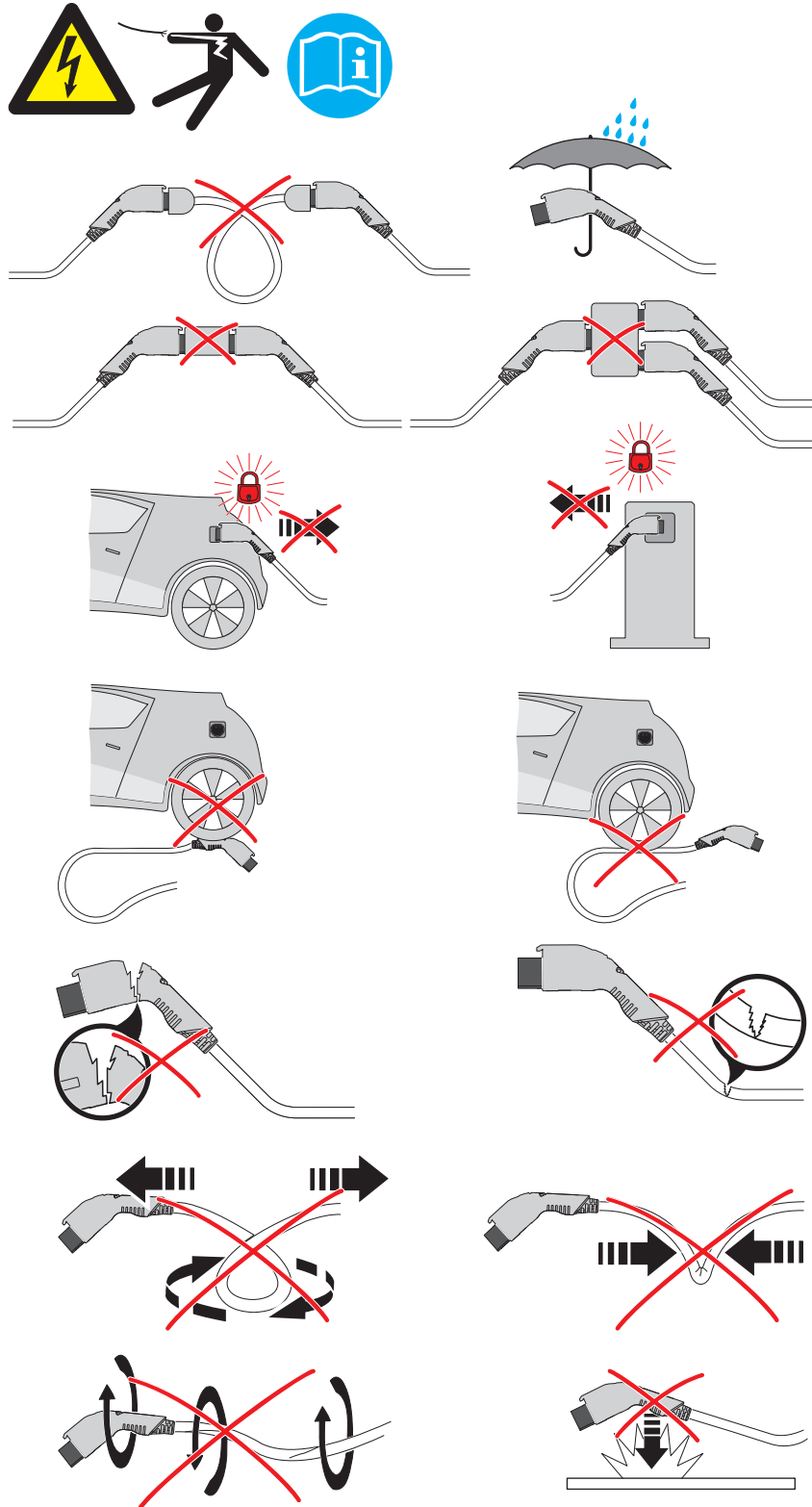

## DC charging cable - EV-T2HPCC-DC500A-5,0M50ECBK11 - 1085638

### Classifications

eCl@ss

eCl@ss 10.0.1	27144705
eCl@ss 11.0	27144705
eCl@ss 9.0	27144705

ETIM

ETIM 6.0	EC002897
ETIM 7.0	EC002897

### Accessories

#### Accessories

##### Cable handle

Cable handle - EV-GRIP-D35,7MM - 1091431



CHARX connect, Cable handle, For vehicle charging connector, High Power Charging, IEC 62196-3, HPC, Please note: The item can only be used with the outer cable diameter indicated.

---

#### Cooling unit

Cooling unit - EV-HPC-PCU-01 - 1237881



CHARX connect, Cooling unit, passive, semi-closed cooling circuit, variable-speed fan, variable-speed pump, for cooling the cooling liquid of a Phoenix Contact HPC DC charging cable, for installation in e-mobility charging stations (EVSE), High Power Charging, CCS type 1, CCS type 2, straight, length: 1.5 m

---

#### Full screw connection

Cable gland - G-INS-M50-L68L-PNES-BK - 1411138



Cable gland, cable gland material: PA, external cable diameter 30 mm ... 36 mm, shielding: no, connecting thread: M50 x 1.5, color: jet black RAL 9005

---

#### Repair kit

## DC charging cable - EV-T2HPCC-DC500A-5,0M50ECBK11 - 1085638

### Accessories

#### Repair kit - EV-T2CCS-MF-M4X10-BIT-CTS - 1085799



CHARX connect, Repair kit, with replaceable mating face frame, with 5x M4X10 rounded head screws with Torx safety drive, with special bit for safety screwdriver, with DC contact maintained with integrated front part of DC contacts and their temperature sensors, For replacement of the mating face frame of vehicle charging connectors, CCS type 2, Combined Charging System, High Power Charging, IEC 62196-3-1, HPC, Replacement without draining the coolant

---

#### Repair kit - EV-T2CCS-MF-M4X10-BIT - 1085798



CHARX connect, Repair kit, with replaceable mating face frame, with 5x M4X10 rounded head screws with Torx safety drive, with special bit for safety screwdriver, For replacement of the mating face frame of vehicle charging connectors, CCS type 2, Combined Charging System, High Power Charging, IEC 62196-3-1, HPC, Replacement without draining the coolant

---

#### Repair kit - EV-T2CCS-MF-M4X10 - 1085797



CHARX connect, Repair kit, with replaceable mating face frame, with 5x M4X10 rounded head screws with Torx safety drive, For replacement of the mating face frame of vehicle charging connectors, CCS type 2, Combined Charging System, High Power Charging, IEC 62196-3-1, HPC, Replacement without draining the coolant